

THE CONDENSING CYCLE FOR HEAT ENGINES WITH OPERATING TEMPERATURES FROM 50 TO 100°C'

Müller G.

Faculty of Engineering and the Environment,
University of Southampton,
Southampton SO17 1BJ,
UK,

E-mail: g.muller@soton.ac.uk

ABSTRACT

Low grade thermal energy with low temperatures of up to 150° C occurs e.g. as waste heat or waste steam in industry, or in renewable energy systems such as solar thermal collectors or geothermal systems. The cost-effective utilisation of such low-grade thermal energy still constitutes an engineering challenge. Existing technology such as Organic Rankine Cycle systems is complex, and only cost-effective for power ratings of 500 kW and more. At Southampton University, the condensing steam cycle, which has an operating temperature of 100C and was originally proposed by James Watt in 1782, was re-examined. The theoretical efficiency at 100°C ranges from 0.064 for a simple condensing engine to 0.174 for a steam expansion ratio of 1:8. A 30 Watt model engine confirmed the efficiency increase. Further theoretical work indicates that operating temperatures as low as 50°C with an efficiency of 0.06 could be possible, still using water as working fluid. The condensing engine is a simple machine which could provide a cost-effective solution for low-grade heat conversion.

INTRODUCTION

Low grade thermal energy with temperatures of up to 150° C occurs as waste heat in industry, as waste steam, and as the product of renewable energy systems such as solar thermal collectors or geothermal systems. The cost effective utilisation of this resource however still constitutes an engineering challenge. Available technologies such as the Organic Rankine Cycle (ORC), which can employ organic working fluids (refrigerants) with evaporation temperatures well below 100°C, are complex, operate at high pressures of 6 to 20 bar, and are therefore expensive, see e.g. the overview in [2]. Recent tests with an ORC installation with an operating temperature of 78.1 to 93.7°C gave energetic (waste heat to electricity) efficiencies of 0.062 to 0.076 [3]. Assuming a generator efficiency of 0.9, the actual mechanical efficiency can then be estimated to range from 0.074 to 0.084. In another study, theoretical efficiencies for ORC engines with an operating temperature of 72.6 and 100°C were determined as 0.092 and 0.129 [4]. These calculations included an internal heat exchanger. The complex technology of ORC systems means that power ratings of several hundred kW and more are required for cost-effective operation. Other concepts such as fluid piston machines, thermoelectric conversion or thermal expansion machines are still in the experimental stage. There is therefore a need for a simple, cost-effective technology for low grade heat utilisation,

and here in particular for the lower power range from 5 to 100 kW.

A historic but forgotten technology, the condensing engine, could be of interest here [5]. It is a simple machine which operates with a temperature of 100°C and at atmosphere pressure. It uses water as a cheap, non-toxic, not inflammable and non-corrosive working fluid and therefore avoids several of the disadvantages of ORC systems. Its main disadvantage is the comparatively low efficiency. Recent theoretical and experimental work at the University of Southampton has however demonstrated that the efficiencies of the atmospheric cycle can be increased substantially [6].

NOMENCLATURE

c_p	[J/kg·K]	specific heat of water
c_{st}	[J/kg·K]	specific heat of steam
m	[kg]	mass of steam volume
n	[-]	Expansion ratio L_0 / L_1
p_0	[Pa]	boiler pressure
p_1	[Pa]	steam pressure (adiabatic expansion)
p_2	[Pa]	condenser pressure
A_p	[m ²]	Area of piston (assumed to be equal to 1)
E_{iso}	[J]	Thermal energy required during isothermal expansion of steam
E_{th}	[J]	Thermal energy required for steam generation
F_0	[N]	Force generated by pressure p_0
H_L	[J/kg]	Latent heat of water
ΔL	[m]	Length of expansion
L_0	[m]	Length of cylinder filled with steam of pressure p_0
L_1	[m]	Length of cylinder
T_0	[K]	boiler temperature
T_1	[K]	Steam temperature (adiabatic expansion)
T_2	[K]	condenser temperature
T_{ev}	[K]	evaporation temperature of water
W_0	[J]	Work conducted at pressure p_0
W_1	[J]	Expansion work during adiabatic expansion
W_2	[J]	Counteracting work generated by the condenser pressure p_2
W_{tot}	[J]	Total work generated during an adiabatic expansion stroke
γ	[-]	Adiabatic coefficient
η	[-]	adiabatic efficiency

THE CONDENSING STEAM ENGINE

The steam condensation cycle allows for the generation of mechanical energy from steam at atmospheric pressure. The historic atmospheric steam engine, which was invented by Thomas Newcomen in 1712, used this mechanism. In this process, steam is drawn into a cylinder. The steam is then condensed, e.g. by injection of cold water, and the arising

vacuum – or rather the atmospheric pressure acting from outside the system – drives the machine. James Watt improved the cycle by introducing an external condenser, which led to the condensing engine (CE) in 1772, [5]. The external condenser allowed the cylinder to remain hot, reducing energy losses and improving efficiency. Fig. 1a shows a typical condensing engine (CE) with the working cylinder, condenser and air pump on the left and the drive shaft and flywheel on the right.

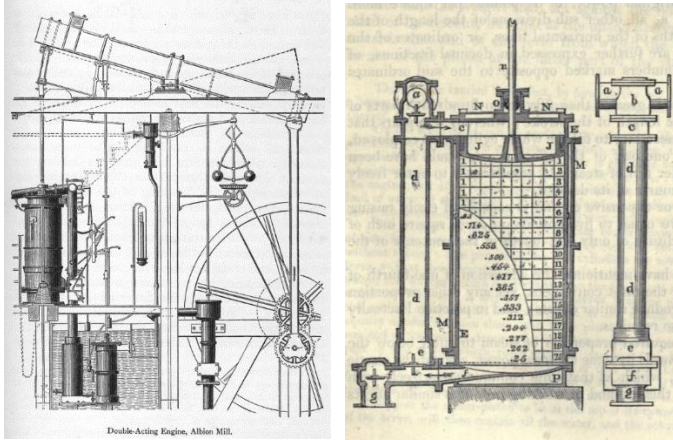

Figure 1 Watt’s Engine (a) typical beam engine (b) steam expansion

The CE’s efficiency is however limited to a theoretical maximum of 6.4%, since only the atmospheric displacement work of the evaporation process can be recovered. Actual efficiencies were estimated as 3 % [5].

In order to smoothen the power generation, James Watt introduced the double acting expansion engine, e.g. [7]. In this machine, steam was alternatively drawn into the cylinder and then condensed on both sides of the piston to allow for a more even generation of torque. The cycle can be described as follows:

At the start of the stroke, the piston is in its upmost position. The pressure on the piston’s top side, which is connected to the boiler, is equal to the boiler pressure, i.e. atmospheric or slightly above. The pressure below the piston is close to absolute zero due to the condensation of the steam. The pressure difference then drives the piston to its lowermost position, where the boiler valve is closed, the steam condensed and the cycle is repeated in the opposite direction. Watt also realised, that due to the pressure difference at the end of the stroke, the steam still contained energy which could be employed to drive the engine. He therefore suggested to cut off the steam supply during the stroke, and let the steam expand to extract most its energy. In this way, a higher efficiency could be reached. In practice, the resulting variability of pressure and power output was highly undesirable since e.g. pumping required a constant force output. The steam expansion was therefore limited to a factor of 1:1.3 to 1:2. Higher expansion ratios were deemed unworkable. James Watt and John Southern also introduced the pressure-volume diagram to analyse the power generated during every stroke, and to determine the efficiency, Fig. 1b. In this analysis, isothermal conditions were implicitly applied. This was however kept as a trade secret, and

only published anonymously in 1822 [8]. The last practical condensing engine, with a power of 0.8 kW at 125.7 rpm and an estimated efficiency of 3.5% was proposed in 1886 by H. Davey of Leeds / England for reasons very similar to those outlined here, namely the safety aspects and simplicity [9]. Davey’s engine did however not employ steam expansion. The expansion from atmospheric to pressures below atmospheric remained a little known aspect of condensing engines, considered of historic interest only, and disappeared with them.

Today, steam expansion is mostly connected with the expansion of pressurized steam in so-called compound engines. The work on the expansion of pressurized steam rather than that of steam at atmospheric pressure really began with Arthur Woolf’s development of the expansion engine in 1805 [10], which then led to the well-known double and triple expansion engines. This cycle is however not covered in his article.

The advantages of the condensing engine, i.e. operation at atmospheric pressure, reduced safety requirements and maintenance costs, simplicity and the possibility to utilise low-grade heat, were apparently outweighed by the low efficiency.

In the early 19th century, when the Condensing Engines disappeared, thermodynamic theory was just at its beginning. To the authors’ knowledge, the sub-atmospheric expansion of the steam was therefore never analysed using ‘modern’ thermodynamics and assessing e.g. the effect of adiabatic and isothermal conditions. No further technical application of the condensing engine appears to exist apart from an interesting variation of the Newcomen Engine, which was developed to power micro-electronic devices [11].

Recently, the theory of the atmospheric process was therefore revisited, theoretically analysed and the effect of steam expansion experimentally assessed in a fundamental experiment [6]. Experimental efficiencies reached values of 0.10, exceeding the theoretical maximum of 0.064 for the condensation cycle without expansion. The results indicated that the expansion cycle does have the potential for improvement, and that the principle could form the basis for a simple and efficient heat engine for operating temperatures of 100°C. Further work is required to develop the theory, and to assess the potential and limitations of the condensing engine with steam expansion. In the following section, the theory of the CE will be described and expanded to include operational temperatures of 50 to 100°C.

THE EXPANSION CYCLE

Description

The condensing engine with boiler, double acting cylinder and condenser is shown in, Fig. 2a. The boiler temperature T_0 is assumed to be 100°C or slightly higher, so that the boiler pressure p_0 is equal to the atmospheric pressure. In the initial stage, Fig. 2a (i), the piston P is at the top position “1”, with the boiler pressure p_0 acting on its top. With a piston area $A_P = 1$, the pressure results in a force $F_0 = A_P \cdot p_0$ on the piston. The space below the piston had been filled with steam, which was condensed as the piston reached the topmost position. After condensation, the pressure p_2 in the cylinder below the piston is close to zero absolute pressure. The pressure difference $p_0 - p_2$ acts on the piston from above, driving it downwards through a

distance L_0 from position “1” to position “2”, Fig. 2a(ii). At point “2”, the boiler valve is closed. The pressure p_2 below the piston remains close to zero, the steam expands over a distance ΔL and the pressure on the piston reduces from p_0 at “2” to p_1 at point “3”, Fig. 2a(iii). With the volume of steam known, and assuming the initial distance between points “1” and “2” to be $L_0 = 1$, and the total stroke length L_1 to be $L_1 = n \cdot L_0$, the energy required for the generation of steam and the work conducted by the piston can be determined.

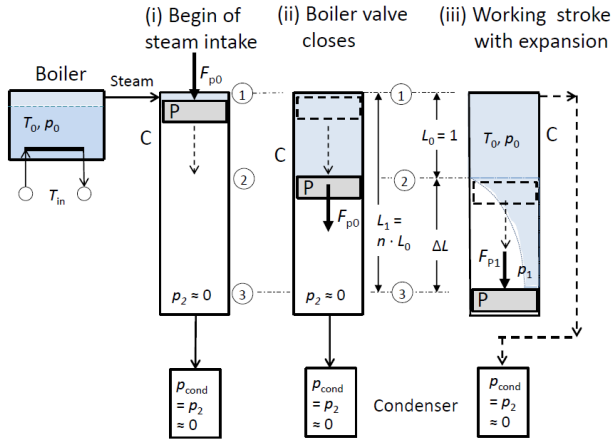

Figure 2 The condensing cycle with expansion

In a real engine, the piston is linked to a piston rod and a flywheel. The inertia of the wheel then carries the piston over the top and bottom dead point.

The condensing cycle

The initial thermal energy E_{th} required to generate the steam can be calculated using the tabulated values for density of water ρ , specific heat c_p and the latent heat of evaporation H_L . With a temperature difference dT , a mass m and a thermal capacity of the water of $c_p = 4.2 \text{ kJ/kg} \cdot \text{K}$ this energy becomes

$$E_{th} = m \cdot (dT \cdot c_p + H_L) \quad (1)$$

The thermal energy required to heat the water up to the evaporation temperature, and to evaporate it amounts to 1529.5 kJ/m^3 for $T = 100^\circ\text{C}$ and $p = 1 \text{ bar}$, with a mass of steam of 0.59 kg/m^3 .

The adiabatic cycle

The initial work W_0 conducted by the steam as the piston moves from position “1” to “2” over a length $L_0 = 1$ under constant pressure is

$$W_0 = p_0 \cdot L_0 \quad (2)$$

At point “2”, the boiler valve is closed and the piston moves from position “2” to “3”, driven by the expanding steam. Assuming an adiabatic expansion with an adiabatic coefficient of $\gamma = 1.08$ for wet steam, the end pressure p_1 becomes:

$$p_1 = p_0 \left(\frac{L_0}{L_1} \right)^{1/\gamma} \quad (3)$$

During the expansion from L_0 to L_1 , the pressure of the steam drops from p_0 to p_1 and the steam conducts the expansion work W_1 :

$$W_1 = \frac{1}{\gamma-1} (p_0 \cdot L_0 - p_1 \cdot L_1) \quad (4)$$

In order to determine the actual work, the counteracting pressure p_2 needs to be considered as well. This creates a work $W_2 = p_2 \cdot L_1$. The total work W_{tot} conducted during a stroke of length L_1 then becomes:

$$W_{tot} = W_0 + W_1 - W_2 = p_0 \cdot (L_1 - L_0) + \frac{1}{\gamma-1} (p_0 \cdot L_0 - p_1 \cdot L_1) - L_1 \cdot p_2 \quad (5)$$

After expansion, the condenser valve at the top of the cylinder is opened, the steam condenses with a pressure $p_2 = 4.25 \text{ kPa}$, corresponding to the condensation temperature of 30°C , and the cycle repeats itself in the opposite direction.

With the thermal energy E_{th} required to produce the steam known from Eq. (1), the efficiency η can be calculated:

$$\eta = \frac{W_{tot}}{E_{th}} \quad (6)$$

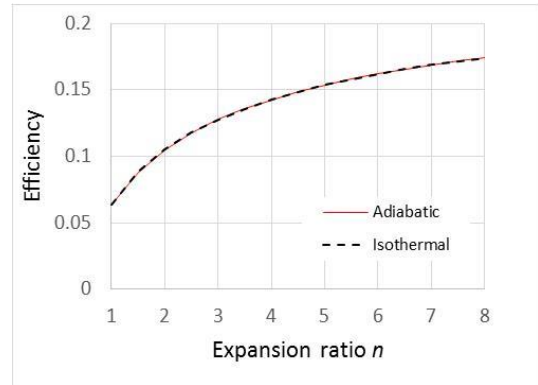

Figure 3 Theoretical efficiency as function of the expansion ratio for adiabatic and isothermal conditions

Fig. 3 shows the theoretical efficiency for adiabatic and isothermal expansion for the classic expansion engine with an operational temperature of 100°C . The theoretical efficiency increases from $\eta = 0.0635$ for an expansion ratio of $n = 1$ (i.e. no expansion) to 0.174 for $n = 8$. This constitutes a substantial improvement over the simple condensing engine. Interestingly, James Watt’s results [7] led to an efficiency of 0.196 , fairly close to the values from “modern” theory.

OPERATING TEMPERATURE 50 TO 100°C

Steam properties

The evaporation temperature of water is a function of the external pressure. It ranges from 46°C for a pressure of 0.10 bar or 10 kPa to 100°C at atmospheric pressure $p_{atm} = 100 \text{ kPa}$. A reduction of pressure also reduces the density of the steam from 0.59 kg/m^3 at atmospheric pressure to 0.068 kg/m^3 for $T_{ev} = 46^\circ\text{C} / p = 0.10 \text{ bar}$. The latent heat of evaporation increases slightly, from $2,258 \text{ kJ/kg}$ at atmospheric pressure to $2,393 \text{ kJ/kg}$ at 10 kPa (absolute). The system shown in Fig. 2a is a closed system, and will operate as long as the boiler temperature T_0 and boiler pressure p_0 are higher than the condenser temperature and pressure T_2 and p_2 . This allows for

the possibility to operate a heat engine with water as working fluid at temperatures below 100°C. Using the appropriate values for steam density, heat capacity and latent heat of evaporation as function of the operating pressure, the efficiencies for adiabatic and isothermal expansion can be determined using the equations given above. Again the condenser temperature and pressure are assumed as $T_2 = 30^\circ\text{C}$ and the corresponding pressure $p_2 = 4.25 \text{ kPa}$ (abs.).

Efficiency

Fig. 4 shows the efficiency as a function of the temperature and for five different expansion ratios of $n = 1$ (no expansion) as reference case to $n = 5$. It also shows the Carnot efficiency as the theoretical upper limit for the conversion process.

The efficiencies for adiabatic and isothermal expansion are very nearly identical for higher temperatures. The efficiencies are highest for the situation with the boiler pressure equal to atmospheric, and $T_0 = 100^\circ\text{C}$. They range from 0.064 for $n = 1$ (no expansion) to 0.154 for $n = 5$. For $T_0 = 50^\circ\text{C}$ the efficiency is lower, and reaches 0.041 for $n = 1$, and 0.061 for $n = 2$. For the lower temperature range ($T_0 < 90^\circ\text{C}$) and adiabatic conditions, the expansion can lead to a drop in steam temperature below the condensation temperature. This would occur for an expansion ratio of 1:2 at 75° , for $n = 1:3$ at 80°C . The theoretical values are however strongly affected by the choice of the adiabatic coefficient. It is here taken as $\gamma = 1.08$, but in the literature, e.g. [12], smaller values of up to 1.035 are also mentioned which would allow for adiabatic expansion throughout. The Carnot efficiency also shown in Fig. 4 is the limiting value for the cycle efficiency. For working temperatures below 70°C , the isothermal process efficiencies approach this limit whilst for higher temperatures between 70 and 100°C , the Carnot efficiency exceeds the process efficiency ($T_0 = 100^\circ\text{C}$, $n = 8$). This indicates the efficiency of the energy conversion process.

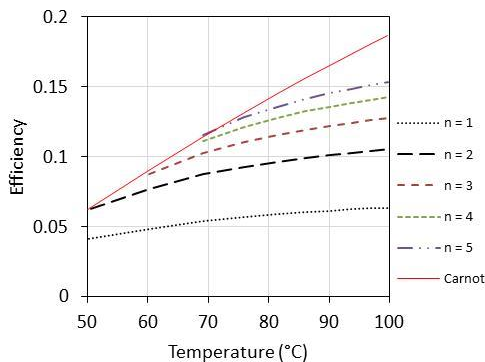

Figure 4 Isothermal efficiency as function of operating temperature and expansion ratio n ($\gamma = 1.08$)

EXPERIMENTS

Overview and schematics

In order to assess the theoretical predictions, and to get some experience with practical aspects of a condensing engine, a 30 Watt model with a cylinder with 120 mm stroke and 50 mm diameter was built. Tests started in March 2017. The

design was based on information given in [6]. The model had electronic valve control, and operated with expansion ratios of $n = 1$ to $n = 3$ at $T_{op} = 100^\circ\text{C}$. Fig. 5 shows the engine schematic. In the downstroke, the steam is admitted through the solenoid S1 to the cylinder. The pressure below the piston is close to zero. As the piston reaches its lowermost point, S1 is closed, and S2 opened to allow steam into the bottom half. Simultaneously S3 is opened, which connects the top half of the cylinder with the condenser. The steam rushes into the condenser, condenses and a vacuum forms.

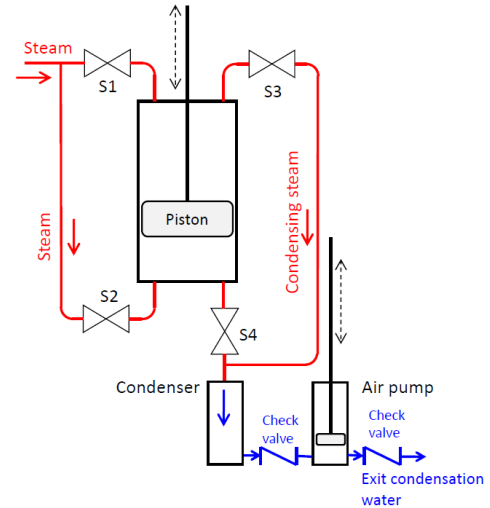

Figure 5 Mk 2 condensing engine, schematic

When the piston reaches the lowermost position, the cycle is reversed. The air pump maintains the vacuum in the condenser. It evacuates the condensed water from the condenser in the upstroke, and ejects it to the outside in the downstroke.

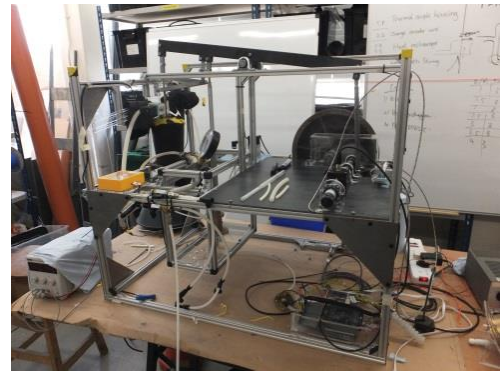

Figure 6 Mk 2 condensing engine model, $P = 30 \text{ Watt}$

The engine had a 320 mm diameter flywheel, which was linked to the driveshaft with a 1:3 transmission, Fig. 6. The weight of the piston was balanced by the eccentric weight of the crank shaft. The engine operated successfully with speeds of 30 to 126 rpm.

Results

Fig. 7 shows a typical tests run with an expansion ratio of $n = 1.5$. In this test, the engine reached an efficiency of 0.033. The graph illustrates some of the difficulties experienced. In the downstroke, the top cylinder pressure is 0.2 bar lower than the

boiler pressure (valve losses?) whilst the bottom cylinder pressure is close to the condenser pressure of 0.25 bar. During the upstroke, the top pressure is 0.15 to 0.2 bar higher than the condenser pressure, whilst the bottom cylinder (filled with steam) is 0.3 bar lower than the boiler pressure. As a result, the power output during the upstroke is significantly smaller than during the downstroke.

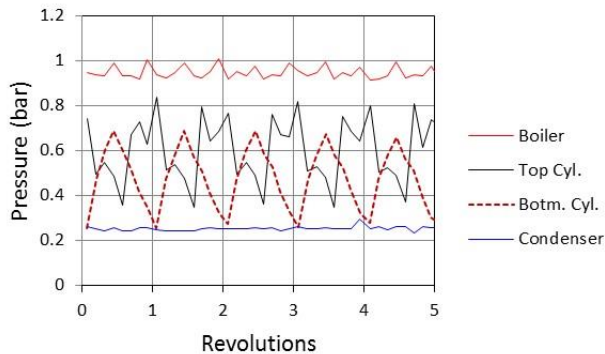

Figure 7 Boiler, cylinder and condenser pressures, $n = 1.5$

The efficiencies at the piston were determined as 0.0244 for $n = 1$, 0.048 for $n = 2$ and 0.050 for $n = 3$. This constituted 44%, 47% and 42% of the theoretically achievable efficiency for the given pressure difference.

Problems were found with

(a) the condenser pressure: it depended on the expansion ratio and reached a minimum only 0.15 bar (abs.) for $n = 4$, to 0.45 bar (abs) for $n = 1$. The target pressure of 0.1 bar (abs) could not be reached. This was caused by the cooling capacity of the condenser.

(b) the cylinder pressures: the pressure in the cylinder top did not exceed 0.9 bar (abs.), and 0.8 bar (abs) in the bottom of the cylinder. This was thought to be caused by condensation inside the valves and the steam pipes at S2 and S3.

In Fig. 5 it can be seen that both problematic seam lines contain low points where condensation may collect. There is also the possibility of condensation water collecting at the top of the cylinder. These problems can however be addressed, and in general it was felt that further substantial improvements of the engine performance are within reach.

Subatmospheric evaporation

In some test runs, the steam demand exceeded the supply. This occurred mostly for operation without expansion, i.e. $n = 1$. It led to a situation where the boiler pressure dropped down to 0.78 bar (abs.), Fig. 8, corresponding to a boiler temperature of approximately 90°C. The efficiency is still at 0.024. So, even at a boiler temperature well below 100°C, the engine ran and delivered power. The concept of sub-atmospheric evaporation was therefore demonstrated more or less accidentally.

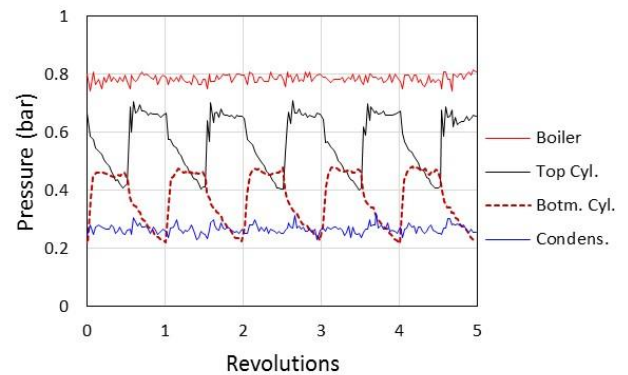

Figure 8 Boiler, cylinder and condenser pressures, $n = 1.0$, $T_0 \approx 90^\circ\text{C}$, $p_0 = 0.78$ bar (abs.)

DISCUSSION

Engine performance

The classic condensing engine operates with temperatures of 100°C, and atmospheric pressure. The efficiencies range from 0.064 (no expansion) to 0.174 for an expansion ratio of 1:8. The extension of the theory into the temperature range below 100°C led to maximum efficiencies of 0.159 (expansion ratio $n = 1:8$) at $T_0 = 90^\circ\text{C}$ and 0.061 (expansion ratio 1:2) at $T_0 = 50^\circ\text{C}$. The condensing engine offers very interesting advantages for the utilisation of low-grade heat:

- Operating temperatures range from 50 to 100°C.
- Water is a cheap, non-toxic and inflammable working fluid.
- Sealing, maintenance and operation at atmospheric pressures or below is far less demanding than it is e.g. in ORC systems with pressures of 6 to 20 bar.
- Small leakages can be tolerated (working fluid is water).
- The CE is a very simple, i.e. cost-effective machine. With modern control technology and materials the cost-effectiveness can be improved further.

Safety, inspection and maintenance as well as the certification requirements connected with pressurized systems (operating temperature $> 100^\circ\text{C}$, pressure $p_{op} > 1.5$ bar absolute) do not apply to the Condensing engine. This gives such a system substantial investment and maintenance cost advantages [13].

The experiments showed that the operation with steam expansion is possible, and that it increases the efficiency. The actual efficiencies reached already exceeded those reported in the literature. The experiments also highlighted some technical problems connected with the condenser cooling, valves and steam pipes. Flow resistance of, and condensation in valves needs to be addressed in the next development stage as well as the cooling demand from the condenser.

Thinking further ahead, other options open up. Conventional steam engines are built from metal. The low operating temperatures and pressures of the CE may make the use of high precision plastic material for cylinder and piston possible, thereby reducing costs substantially.

The main disadvantages of the sub-atmospheric condensing engine would be the large cylinder volume required, and the

variability of torque during each stroke. For both reasons, multi-cylinder arrangements will very probably be required.

CONCLUSIONS

The theory of the condensing engine with expansion was developed, and expanded to include the temperature range from 50 to 100°C. Experiments with a 30 W model engine with operating temperatures of 100 and 97°C were conducted. It was found that:

- Operating temperatures down to 50°C with water as working fluid are theoretically possible, although the efficiency reduces with reducing temperature.
- The theoretical efficiencies range from 0.04 (no expansion) and 0.061 (expansion ratio 1:2) at $T_0 = 50^\circ\text{C}$ to 0.064 (no expansion) and 0.174 (expansion ratio $n = 1:8$) at $T_0 = 100^\circ\text{C}$.
- Theoretical efficiencies reach 95% of the *Carnot* limit for $T_0 = 100^\circ\text{C}$, and 99% for $T_0 = 50^\circ\text{C}$. The condensation cycle can therefore be considered as efficient.
- An experimental engine had efficiencies of 0.024 to 0.048 and 5.04% (expansion ratios of $n = 1, 2$ and 3 respectively) corresponding to 44%, 47% and 42% of the theoretically possible values. Improvements are possible.
- The concept of subatmospheric evaporation was demonstrated experimentally.

The theoretical investigation demonstrated that the condensing cycle with sub-atmospheric evaporation has the potential to form the basis for a simple and efficient heat engine for low grade heat. Experiments confirmed the validity of the concept of the condensing engine, indicated its potential and highlighted areas where improvements are necessary.

REFERENCES

- [1] Pehnt, M., Bödeker, J., Arens, M., Jochem, E., Idrissova, F., & Heidelberg, K. (2010). Die Nutzung industrieller Abwärmetechnisch-wirtschaftliche Potenziale und energiepolitische Umsetzung des Vorhabens. Report FKZ 03KSW016A und B.
- [2] Tchanche, B. F., Lambrinos, G., Frangoudakis, A., & Papadakis, G. (2011). Low-grade heat conversion into power using organic Rankine cycles—A review of various applications. *Renewable and Sustainable Energy Reviews*, 15(8), 3963-3979.
- [3] Minea, V. (2014). Power generation with ORC machines using low-grade waste heat or renewable energy. *Applied Thermal Engineering*, 69(1), 143-154.
- [4] Saleh, B., Koglbauer, G., Wendland, M., & Fischer, J. (2007). Working fluids for low-temperature organic Rankine cycles. *Energy*, 32(7), 1210-1221.
- [5] Dickinson HW. A short history of the steam engine. Cambridge: Cambridge University Press; 1938.
- [6] Müller, G., & Parker, G. (2015). Experimental investigation of the atmospheric steam engine with forced expansion. *Renewable Energy*, 75, 348-355.
- [7] Farey, J. (1827). A Treatise on the Steam Engine Historical, Practical, and Descriptive. By John Farey. Illustrated by Numerous Engravings and Diagrams. Longman, Rees, Orme, Brown, and Green.
- [8] Anonymous (1822). Account of a steam-engine indicator. *Quarterly Journal of Science*, vol. 13. 95.
- [9] Dingler 1886 (Ed.), Ueber Neuerungen an Kleindampfmaschinen. *Polytechnisches Journal*. Band 259 (S. 1–9).
- [10] Dickinson H.W. (1938) A short history of the steam engine. University Press Cambridge. Cambridge/England.
- [11] Wang, Y., Zhou, Z., Zhou, J., Liu, J., Wang, Z., & Cen, K. (2011). Micro Newcomen steam engine using two-phase working fluid. *Energy*, 36(2), 917-921.
- [12] Dietzel F. and Wagner W. 2006. Technische Wärmelehre. 9th Ed. Vogel Verlag, Würzburg.
- [13] Safety of pressure systems: Pressure Systems Safety Regulations 2000. Approved Code of Practice L122 HSE Books 2000 (www.hse.gov.uk/pubns/books/L122.htm).